

# 4MP Vandal-resistant IR Fixed Mini Dome Camera

IPC314SR-DVPF28 (36)



## Key Features

### Optics

- Day/night functionality
- Smart IR, up to 15 m (49 ft) IR distance
- 3D DNR (Digital Noise Reduction)
- Up to 120 dB Optical WDR(Wide Dynamic Range)

### Compression

- H.265, H.264, MJPEG
- Embedded smart algorithm
- Triple streams
- ROI (Region of Interest)

### Network

- ONVIF Conformance

### Structure

- Wide temperature range: -35°C to 60°C (-31°F to 140°F)
- Wide voltage range of  $\pm 25\%$
- Built-in microphone
- IK10 vandal resistant
- IP66

## Specifications

Camera	IPC314SR-DVVF28	IPC314SR-DVVF36
Sensor	1/3", 4 megapixel, progressive scan CMOS	
Lens	2.8mm@F2.0	3.6 mm@F2.0
Angle of View (H)	101.8°	76.8°
Shutter	Auto/Manual, 1/6~1/100000 s	
Min. Illumination	Colour: 0.02 Lux (F2.0, AGC ON) 0 Lux with IR	
Day/Night	IR-cut filter with auto switch (ICR)	
S/N	≥ 55 dB	
WDR	120 dB	
<b>Video</b>		
Max. Resolution	2592 × 1520	
Video Compression	H.265, H.264, MJPEG	
Frame Rate	4MP (2592×1520): Max. 20 fps; 4MP (2560×1440): Max. 25 fps 3MP (2048×1520): Max. 30 fps; 1080P (1920×1080): Max. 30 fps	
Video Streaming	Triple	
9:16 Corridor Mode	Supported	
ROI	Supported	
Evaluative Metering	Supported	
OSD	Up to 8 OSDs	
Privacy Mask	Up to 8 areas	
<b>Smart</b>		
Behavior Detection	Intrusion, crossing line, motion detection	
Exception Detection	Audio detection	
Intelligent Identification	Face detection, Defocus, Scene Change	
Statistical Analysis	People counting	
<b>Storage</b>		
Edge Storage	Micro SD, Up to 128 GB	
<b>Network</b>		
Protocols	L2TP, IPv4, IGMP, ICMP, ARP, TCP, UDP, DHCP, PPPoE, RTP, RTSP, RTCP, DNS, DDNS, NTP, FTP, UPnP, HTTP, HTTPS, SMTP, 802.1x	
Compatible Integration	ONVIF, API	
<b>Interface</b>		
Audio I/O	Audio cable	
	Input: impedance 35 kΩ; amplitude 2 V [p-p]	
	Output: impedance 600 Ω; amplitude 2 V [p-p]	
Built-in Mic	Supported	
Network	10M/100M Base-TX Ethernet	
<b>General</b>		
Power	12 V DC ± 25%, PoE (IEEE 802.3af)	
	Power consumption: 3~5W	

Dimensions (Ø x H)	Ø110 x 61 mm (Ø4.3" x 2.4")
Weight	0.25 kg (0.55 lb)
Working Environment	-35°C ~ +60°C (-31°F ~ 140°F), Humidity ≤ 95% RH(non-condensing)
Ingress Protection	IP66
Vandal Resistant	IK10

## Dimensions

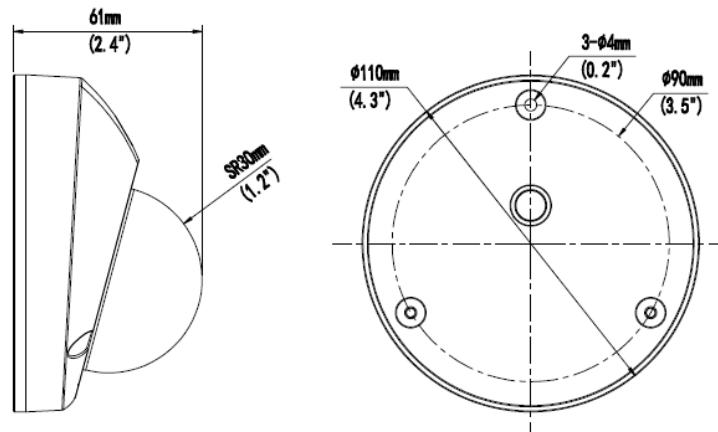

## Installation

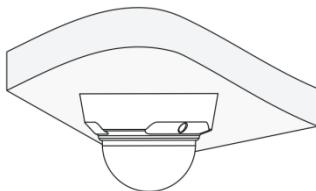

Ceiling mount

## Accessories

Installation mode	Accessories	Description
Ceiling mount	Mounting pedestal is included in the Product package	\

### Zhejiang Uniview Technologies Co., Ltd.

South Tower, Building 10, Wanlun Science Park, 88 Jiangling Road, Hangzhou, P.R.China 310051

Email: [overseasbusiness@uniview.com](mailto:overseasbusiness@uniview.com); [globalsupport@uniview.com](mailto:globalsupport@uniview.com)

<http://www.uniview.com>

©2016-2017 Zhejiang Uniview Technologies Co., Ltd. All rights reserved.

\*Product specifications and availability are subject to change without notice.